

HAITIAN PLASTICS MACHINERY GROUP CO., LTD
No.1688, Haitian Road, Xiaogang, Beilun, Ningbo, Zhejiang,
China 315801
+ 86-574-8617 7005 (China)
+ 86-574-8617 7242 (International)
haitian@mail.haitian.com
www.haitianpm.com

NINGBO HAITIAN HUAYUAN MACHINERY CO.,LTD.
No.1, Nanhuan Road, Export Processing Zone, Beilun,
Ningbo, Zhejiang, 315806 P.R. China
+86-574-8617 7242
+86-574-8622 1864
haitian@mail.haitian.com
www.haitianpm.com



SPECIFICATIONS

GLOBAL



HAITIAN MARS III SERIES

Energy-saving servo injection molding machines

600 - 12,000 kN



SPECIFICATION

TECHNICAL DATA
MACHINE TYPE

		MA600 III /130		MA900 III /280			MA1200 III /400			MA1600 III /570		
		A	B	A	B	C	A	B	C	A	B	C
INJECTION UNIT												
Screw diameter	mm	24	28	32	36	40	36	40	45	40	45	50
Screw L/D ratio		23.3	20	22.5	20	18	23.3	21	18.7	22.5	20	18
Injection volume (theoretical)	cm ³	50	68	121	153	188	173	214	270	253	320	395
Injection weight (PS)	g	45	62	110	139	172	157	194	246	230	291	359
Injection rate	g/s	62	84	99	125	154	125	154	195	149	188	232
Injection pressure	MPa	250	184	234	185	150	229	186	147	225	178	144
Plasticizing rate (GPPS) ①	g/s	6.0	8.6	12.5	16.5	20.0	18.4	22.6	29.8	21.9	29.2	36.7
Plasticizing rate (HDPE) ②	g/s	-	-	-	-	-	-	-	-	-	-	-
Screw speed	rpm	0-310		0-285			0-285			0-265		
CLAMPING UNIT												
Clamping force	kN	600		900			1200			1600		
Mold opening stroke	mm	270		310			360			430		
Dist. between tie bars (H×V)	mm	310×310		360×360			410×410			470×470		
Mold height max.	mm	330		390			450			520		
Mold height min.	mm	120		150			150			180		
Ejector stroke	mm	70		100			120			140		
Ejector force	kN	22		33			33			33		
OTHERS												
Pump motor power	kW	13		15			18.5			22		
Heater power	kW	6.3		7.7			11.75			11.75		
Machine dimension (L×W×H)	m	3.87×1.06×1.89		4.22×1.16×1.95			4.84×1.19×2.05			5.36×1.37×2.10		
Machine weight	t	2.5		3.35			4.35			5.65		
Hopper capacity	kg	25		25			25			25		
Oil tank	l	120		150			170			210		

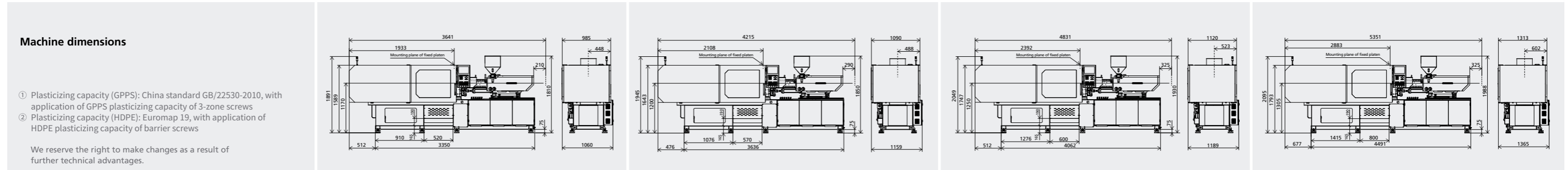
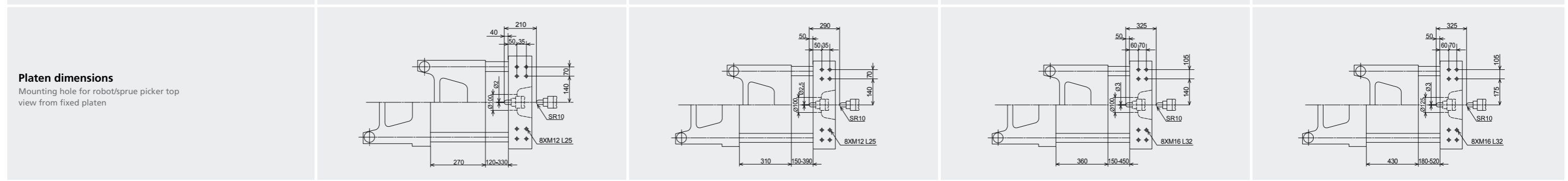
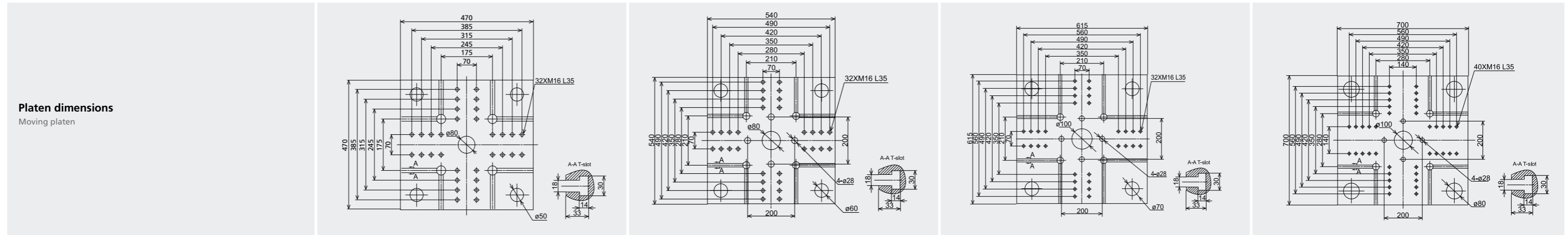

- ① Plasticizing capacity (GPPS): China standard GB/22530-2010, with application of GPPS plasticizing capacity of 3-zone screws
- ② Plasticizing capacity (HDPE): Euromap 19, with application of HDPE plasticizing capacity of barrier screws

We reserve the right to make changes as a result of further technical advantages.

SPECIFICATION

TECHNICAL DATA
MACHINE TYPE

	MA2000 III /750			MA 2500 III /1000			MA2800 III /1350			MA3200 III /1700			
INJECTION UNIT		A	B	C	A	B	C	A	B	C	A	B	C
Screw diameter	mm	45	50	55	50	55	60	55	60	65	60	65	70
Screw L/D ratio		22.2	20	18.2	22	20	18.3	21.8	20	18.5	21.7	20	18.6
Injection volume (theoretical)	cm ³	334	412	499	471	570	679	618	735	863	792	929	1078
Injection weight (PS)	g	304	375	454	429	519	618	562	669	785	720	846	981
Injection rate	g/s	188	232	281	232	281	335	281	334	392	296	347	403
Injection pressure	MPa	223	180	149	224	185	155	223	188	160	213	182	157
Plasticizing rate (GPPS) ①	g/s	24.5	30.8	37.6	38.9	47.7	56.5	45.0	53.4	59.4	51.1	56.7	64.4
Plasticizing rate (HDPE) ②	g/s		-			-			-		72	81	94.5
Screw speed	rpm		0-205			0-240			0-250			0-225	
CLAMPING UNIT													
Clamping force	kN		2000			2500			2800			3200	
Mold opening stroke	mm		490			540			590			640	
Dist. between tie bars (HxV)	mm		530x530			580x580			630x630			680x680	
Mold height max.	mm		550			580			630			680	
Mold height min.	mm		200			220			230			250	
Ejector stroke	mm		140			150			150			160	
Ejector force	kN		62			62			62			62	
OTHERS													
Pump motor power	kW		30			37			45			45	
Heater power	kW		16.95			17.8			23.4			27	
Machine dimension (LxWxH)	m		5.85x1.44x2.20			6.17x1.52x2.27			6.62x1.71x2.41			7.09x1.80x2.38	
Machine weight	t		7.1			8.4			11.7			13.5	
Hopper capacity	kg		50			50			50			50	
Oil tank	l		250			340			440			500	

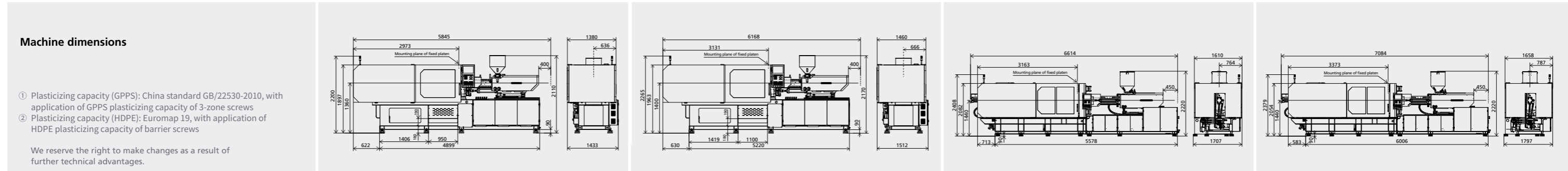
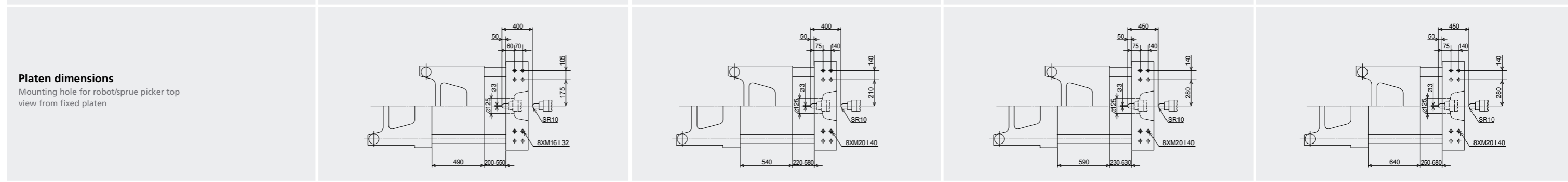
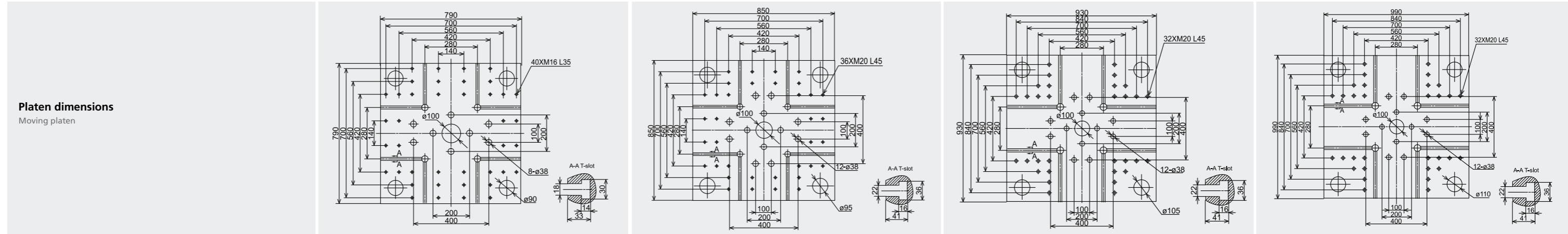

- ① Plasticizing capacity (GPPS): China standard GB/22530-2010, with application of GPPS plasticizing capacity of 3-zone screws
- ② Plasticizing capacity (HDPE): Euromap 19, with application of HDPE plasticizing capacity of barrier screws

We reserve the right to make changes as a result of further technical advantages.

SPECIFICATION

TECHNICAL DATA
MACHINE TYPE

	MA3800 III / 2250				MA4700 III / 3200				MA5300 III / 4500				
	A	B	C	D	A	B	C	D	A	B	C	D	
INJECTION UNIT													
Screw diameter	mm	65	70	75	80	70	80	85	90	80	85	90	100
Screw L/D ratio		21.5	20	18.7	17.5	22.9	20	19.1	17.8	22	20.7	19.6	17.6
Injection volume (theoretical)	cm ³	1068	1239	1423	1619	1424	1860	2100	2354	2212	2497	2799	3456
Injection weight (PS)	g	972	1128	1295	1473	1296	1692	1911	2142	2013	2272	2547	3145
Injection rate	g/s	369	427	491	558	427	558	630	706	558	630	706	872
Injection pressure	MPa	212	183	159	140	224	172	152	136	197	175	156	126
Plasticizing rate (GPPS) ①	g/s	58.6	67.3	76.1	84.4	67.9	89.5	98.3	111.1	78.1	86.3	98.6	119.8
Plasticizing rate (HDPE) ②	g/s	83.8	100	112	126	97.2	131	148	170	113.5	126.2	142.1	175
Screw speed	rpm	0-220				0-210				0-175			
CLAMPING UNIT													
Clamping force	kN	3800				4700				5300			
Mold opening stroke	mm	700				780				850			
Dist. between tie bars (H×V)	mm	730×730				820×800				840×830			
Mold height max.	mm	730				780				850			
Mold height min.	mm	280				320				350			
Ejector stroke	mm	180				200				220			
Ejector force	kN	110				110				158			
OTHERS													
Pump motor power	kW	55				65				22+55			
Heater power	kW	33				38.95				48			
Machine dimension (L×W×H)	m	7.51×1.82×2.33				8.24×1.96×2.55				9.0×2.04×2.72			
Machine weight	t	15.1				19.6				24			
Hopper capacity	kg	50				50				100			
Oil tank	l	540				640				800			

Platen dimensions

Moving platen

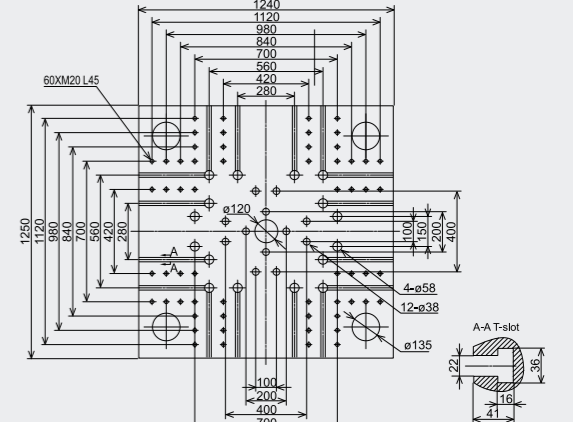
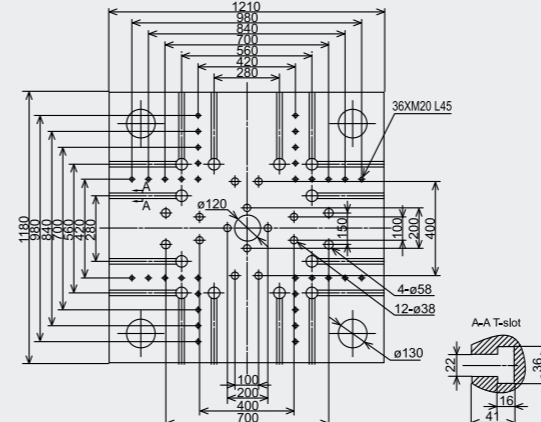
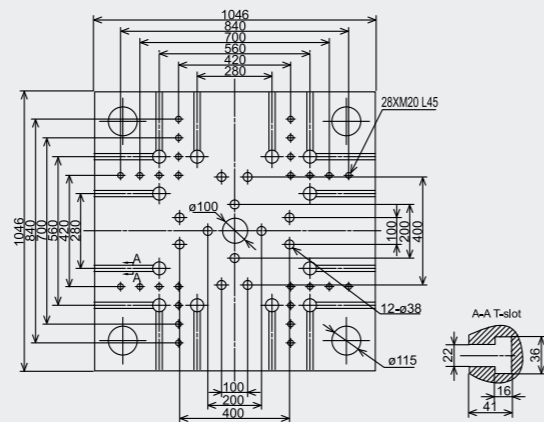

Platen dimensions

Mounting hole for robot/sprue picker top view from fixed platen

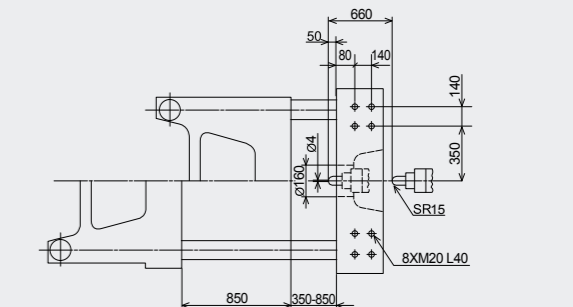
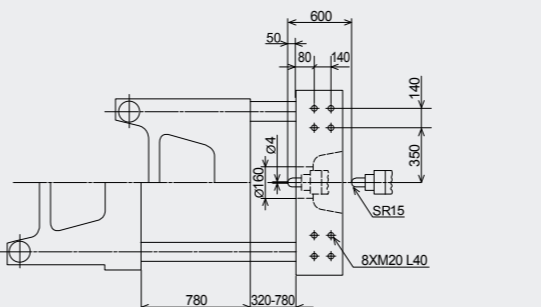
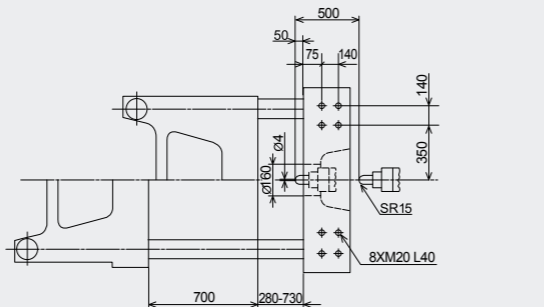

Machine dimensions

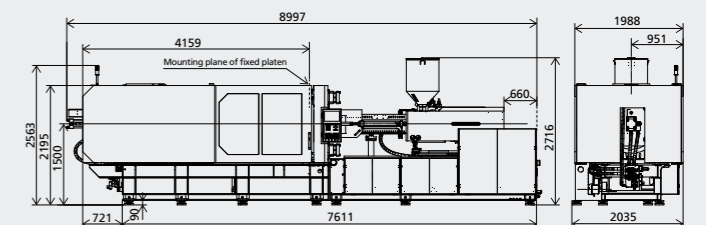
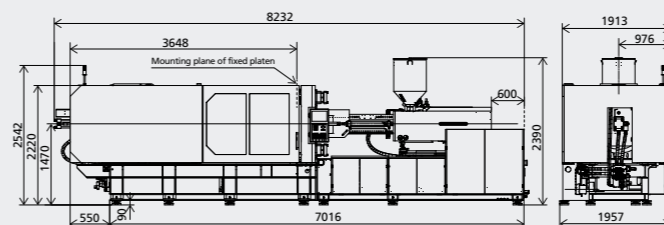
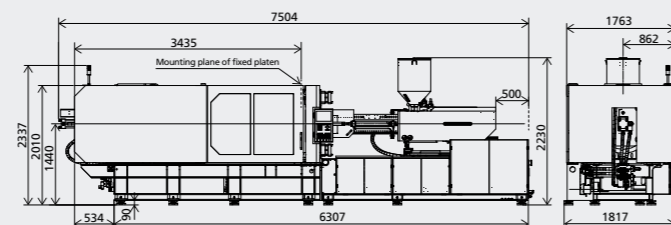

- ① Plasticizing capacity (GPPS): China standard GB/22530-2010, with application of GPPS plasticizing capacity of 3-zone screws
- ② Plasticizing capacity (HDPE): Euromap 19, with application of HDPE plasticizing capacity of barrier screws

We reserve the right to make changes as a result of further technical advantages.

SPECIFICATION

TECHNICAL DATA
MACHINE TYPE

	MA9000 III /6800				MA10000 III /8400				MA12000 III /8400				
	A	B	C	D	A	B	C	D	A	B	C	D	
INJECTION UNIT													
Screw diameter	mm	90	100	110	120	100	110	120	130	100	110	120	130
Screw L/D ratio		24.4	22	20	18.3	24.2	22	20.2	18.6	24.2	22	20.2	18.6
Injection volume (theoretical)	cm ³	2990	3691	4467	5316	4006	4847	5768	6769	4006	4847	5768	6769
Injection weight (PS)	g	2721	3359	4065	4837	3645	4410	5249	6160	3645	4410	5249	6160
Injection rate	g/s	590	729	882	1050	715	865	1030	1208	715	865	1030	1208
Injection pressure	MPa	219	178	147	123	213	176	148	126	213	176	148	126
Plasticizing rate (GPPS) ①	g/s	89.5	110	130	152	100	120	139	160	100	120	139	160
Plasticizing rate (HDPE) ②	g/s	132	162	193	224	146	175	199	229	146	175	199	229
Screw speed	rpm	0-135				0-115				0-115			
CLAMPING UNIT													
Clamping force	kN	9000				10000				12000			
Mold opening stroke	mm	1120				1220				1310			
Dist. between tie bars (HxV)	mm	1080x1080				1160x1160				1250x1250			
Mold height max.	mm	1080				1160				1250			
Mold height min.	mm	450				500				550			
Ejector stroke	mm	300				320				320			
Ejector force	kN	186				215				215			
OTHERS													
Pump motor power	kW	37+55				37+65				37+65			
Heater power	kW	70.6				82.8				82.8			
Machine dimension (LxWxH)	m	11.29x2.42x2.81				12.05x2.49x2.85				12.42x2.61x2.94			
Machine weight	t	45				49				59			
Hopper capacity	kg	100				100				100			
Oil tank	l	1000				1150				1150			

Platen dimensions

Moving platen

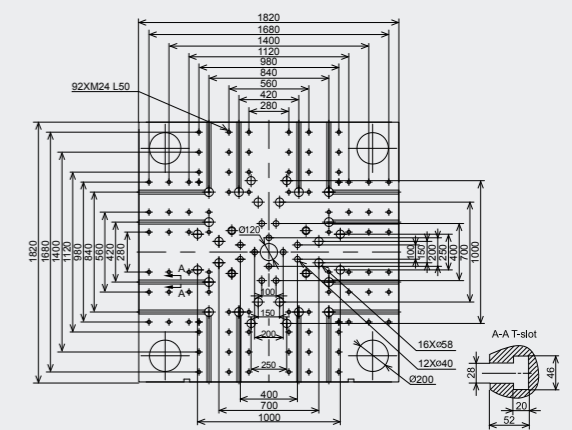
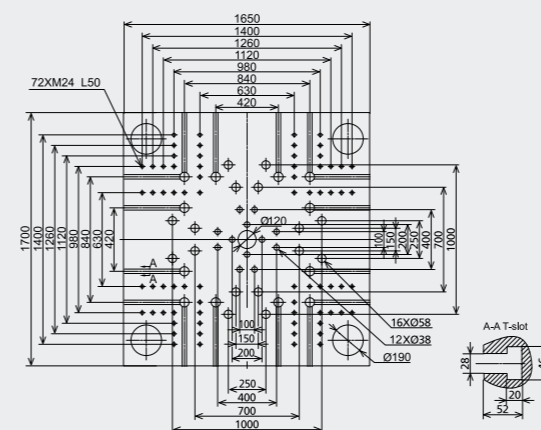
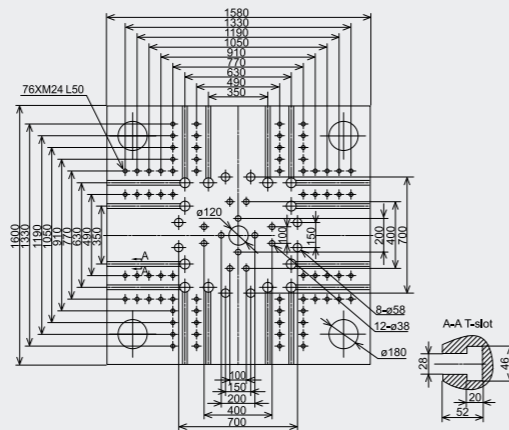

Platen dimensions

Mounting hole for robot/sprue picker top view from fixed platen

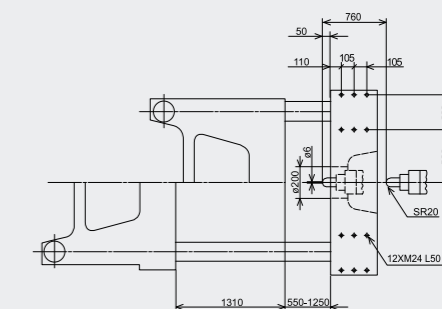
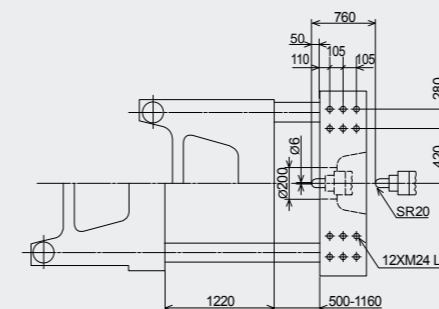
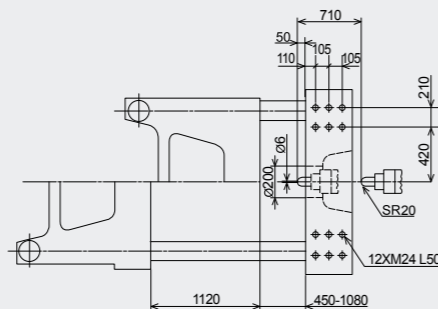

Machine dimensions

- ① Plasticizing capacity (GPPS): China standard GB/22530-2010, with application of GPPS plasticizing capacity of 3-zone screws
- ② Plasticizing capacity (HDPE): Euromap 19, with application of HDPE plasticizing capacity of barrier screws

We reserve the right to make changes as a result of further technical advantages.

